



Operator Manual

Commercial Mower

W436 / 967334301-00

W448 / 967334401-00

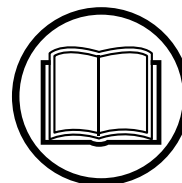

Please read the operator manual carefully and make sure you understand the instructions before using the machine.

EN

Gasoline containing up to 10% ethanol (E10) is acceptable for use in this machine. The use of any gasoline exceeding 10% ethanol (E10) will void the product warranty.



WARNING! Failure to follow cautious operating practices can result in serious injury to the operator or other persons. The owner must understand these instructions, and must allow only trained persons who understand these instructions to operate the unit.

Each person operating the mower must be of sound mind and body and must not be under the influence of any mind altering substance.



WARNING! Engine exhaust, some of its constituents, and certain vehicle components contain or emit chemicals known to the State of California to cause cancer and birth defects or other reproductive harm.



WARNING! Improper assembly or adjustments cause serious injury.



WARNING! Tragic accidents can occur if the operator is not alert to the presence of children. Never assume that children will remain where you last saw them.

IMPORTANT Refer to Engine Manual for correct type and grade of fuel.

IMPORTANT To implement improvements, specifications and designs can be altered without prior notification.

Note that no legal demands can be placed based on the information contained in these instructions.

Use only original parts for repairs. The use of other parts voids the warranty.

Do not modify or install non-standard equipment to the unit without consent from the manufacturer. Modifications to the unit may cause unsafe operations or damage the unit.



WARNING! Stop engine and allow moving parts to stop before leaving operator's position.

Delivery

If you have purchased this product without complete assembly and instruction by your retailer, it is your responsibility to read and understand all assembly instructions. If you do not understand or have difficulty following the instructions, contact the nearest Husqvarna dealer for assistance.

To locate the nearest Husqvarna dealer, go to www.husqvarna.com.

Before Operating the Unit

1. Make sure all assembly has been properly completed.
2. Understand all safety precautions provided in the manuals.
3. Review control functions and operation of the unit. Do not operate the unit unless all controls function as described.
4. Review recommended lubrication, maintenance and adjustment instructions.

Safety Decals

The safety decals on the machine are visual reminders of the important safety information found in this manual. All messages found on the unit must be fully understood and carefully followed.

Always replace missing or damaged safety decals. Replacement decals can be found in the parts manual for the machine and ordered from your dealer.

TABLE OF CONTENTS

SYMBOLS AND DECALS	5
SAFETY.....	6
ASSEMBLY	10
CONTROLS.....	11
OPERATION.....	12
MAINTENANCE SCHEDULE	19
MAINTENANCE	20
STORAGE	26
TROUBLESHOOTING	27

©2014 All rights reserved.
Orangeburg, SC. Printed in U.S.A.

INTRODUCTION

This manual is a valuable document. Read the contents carefully before using or servicing the machine. The following of instructions (use, service, maintenance) by all who operate the machine is important for the safety of the operator and others.

The engine is covered by a separate manual. The manual is included in the literature package shipped with the unit. Refer to this manual for engine service recommendations.

Model And Serial Numbers

When ordering replacement parts or making service inquiries, know the Model and Serial numbers of your unit.

Numbers are located on the product registration form in the unit literature package. They are printed on a serial number label, located on the frame of the unit near the engine.

Engine serial numbers are on the left side of the engine and also below the dipstick tube.

Unit Model and Serial Number

Engine Model and Serial Number

Production Registration

The dealer will register the product at the time of purchase. Registering the product will help the company process warranty claims or contact you with the latest service information.

If the Dealer does not register your product, fill out, sign and return the product registration card or go to: www.husqvarna.com.

All claims meeting requirements during the limited warranty period will be honored, whether or not the product registration card is returned. Keep a proof of purchase if you do not register the unit.

Service

When ordering spare parts, please specify the purchase year, model, type, and serial number. Always use genuine Husqvarna spare parts.

Emission Control System

This equipment and/or its engine may include exhaust and evaporative emissions control system components required to meet U.S. Environmental Protection Agency (EPA) and/or California Air Resources Board (CARB) regulations. Tampering with emission controls and components by unauthorized personnel may result in severe fines or penalties. Emission controls and components can only be adjusted by a Husqvarna dealer or an authorized engine manufacturer's service center. Contact a Husqvarna dealer concerning emission controls and components.

General

In this operator's manual, left and right, backward and forward are used in relation to the machine's normal driving direction.

Transport on Public Roads

Check applicable road traffic regulations before transporting on public roads. If the machine is transported, you must always use approved fastening equipment and ensure that the machine is well anchored.

Operating

This machine is constructed only for mowing grass on lawns and even ground without obstacles such as stones or tree stumps. All other types of uses are incorrect. The manufacturer's directions concerning operation, maintenance, and repairs must be carefully followed.

Lawn mowers and all power equipment can be potentially dangerous if used improperly. Safety requires good judgement, careful use in accordance with these instructions and common sense.

The machine must only be operated, maintained, and repaired by persons familiar with the machine's special characteristics and who are also knowledgeable about the safety instructions. Use only approved repair parts to maintain this machine.

Accident prevention regulations, other general safety regulations, occupational safety rules, and traffic regulations must be followed without fail.

Unauthorized modifications to the design of the machine may absolve the manufacturer from liability for any resulting personal injury or property damage.

SYMBOLS AND DECALS

These symbols are found on the machine and in the operator manual.

Study them carefully so that you know what they mean.

 **WARNING!** Xxxx xxxxxx xxxxx xxxx
 xxxxxxxxxxx xxxxxx xxxxxxxxxxx. xx xxxxxxxx
 xxxx xxxxxx.

Used in this publication to notify the reader of a risk of personal injury or death, particularly if the reader should neglect to follow instructions given in the manual.

IMPORTANT Xxxx xxxxxx xxxxx xxxx
 xxxxxxxxxxx xxxxxx xxxxxxxxxxx. xx xxxxxxxx
 xxxx xxxxxx.

Used in this publication to notify the reader of a risk of material damage, particularly if the reader should neglect to follow instructions given in the manual. Used also when there is a potential for misuse or misassembly.

ROTATING BLADE! Keep hands and feet away. **DO NOT** operate mower unless guards are in operating position or bagger is attached.



Do not put hands near moving belts



Keep hands and feet away from rotating or moving parts

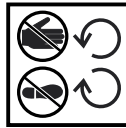

Always stand clear of discharge area.

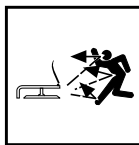

Shut off engine, remove ignition key, read manual before you unplug, adjust or repair unit.

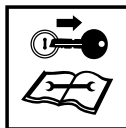

NO STEP! Always keep feet away from rotating parts.



Do not overfill fuel tank. Replace fuel cap securely and clean up spilled fuel. Never fill fuel tank when engine is running, hot or unit is indoors.

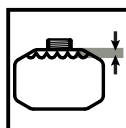

Read the operator manual.

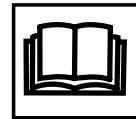

Keep people and pets away when operating unit. Keep children out of the work area and under the watchful care of a responsible adult.

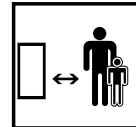

Never direct discharge toward other people. Thrown objects can cause injury. Remove objects that could be thrown by the blade. **DO NOT** operate mower over gravel and hard surfaces.



Keep safety devices (guards, shields, switches, etc.) in place and working.



Look before backing. Proceed off slopes slowly.



Serious injury or death may result from machine rollover. Do not operate on slopes over 15°.



SAFETY

Protecting Children

Tragic accidents can occur if the operator is not alert to the presence of children. Children are often attracted to the machine and the mowing activity. Never assume that children will remain where you last saw them.

- Keep children out of the mowing area and in the watchful care of a responsible adult other than the operator.
- Be alert and turn machine off if a child enters the area.
- Before and while backing, look behind and down for small children.
- Never carry children, even with the blades shut off. They may fall off and be seriously injured or interfere with safe machine operation.
- Never allow children to operate the machine.
- Use extra care when approaching blind corners, shrubs, trees, or other objects that may block your view of a child.



obstacles can injure the operator or interfere with mowing operation. Before mowing, identify potential obstacles such as low-hanging branches, and trim or remove those obstacles.

- Be sure the area is clear of bystanders before operating. Stop machine if anyone enters the area.
- Do not mow in reverse unless absolutely necessary. Always look down and behind before and while backing.
- Never direct discharged material toward anyone. Avoid discharging material against a wall or obstruction. Material may ricochet back toward the operator. Stop the blades when crossing gravel surfaces.
- Do not operate machine without the discharge guard, or other safety devices in place and working.
- Slow down before turning.
- Operate the machine only in daylight or good artificial light.
- Never leave a running machine unattended. Always turn off blades, stop engine and remove ignition key before dismounting.
- Do not wear radio or music headphones. Safe service and operation require full attention.
- Do not hang or secure any item to the control console. The operator's station should always remain unobstructed.
- Do not pull mower backwards while the blades are rotating. Use the reverse gear to move the machine in reverse.
- Disengage blades when not mowing. Shut off engine and wait for all parts to come to a complete stop before cleaning the machine or unclogging the discharge guard.
- Do not operate the machine while under the influence of alcohol or drugs.
- Watch for traffic when operating near or crossing roadways.
- Use extra care when loading or unloading the machine into a trailer or truck.

General Operation

- Read, understand, and follow all instructions on the machine and in the manual before starting.
- Anyone who operates, maintains, and/or services this machine must first read and understand this Operator Manual. Local laws may regulate the age of the user. The owner is responsible for training the users of this equipment.
- The owner and operator of this equipment can prevent accidents and is responsible for accidents or injuries occurring to themselves, other people and/or property.
- Do not put hands or feet near rotating parts or under the machine. Keep clear of the discharge opening at all times.
- Only allow responsible adults, who are familiar with the instructions, to operate the machine.
- Clear the area of objects such as rocks, toys, wire, etc., that could be picked up and thrown by the blades.
- Low-hanging branches and similar

Personal Safety Equipment

- Make sure first aid equipment is close at hand when using the machine.
- Never use the machine when barefoot. Always wear protective shoes or boots, preferably with steel toe caps.
- Always wear approved protective glasses or a full visor when assembling or mowing.
- Always wear gloves when handling the blades.
- Never wear loose clothing that can get caught in moving parts.
- Use ear protectors to avoid damage to hearing.

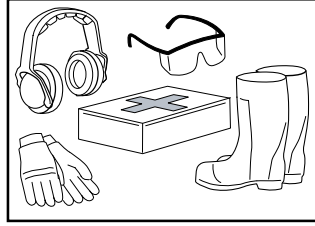

Slope Operation

Slopes are a major factor related to loss of control or machine tip-over accidents, which can result in severe injury or death. Operation on all slopes requires extra caution. If you cannot reverse up the slope or if you feel unsure, do not mow it.

- Mow across slopes, not up and down.
- Watch for holes, ruts, bumps, rocks, or other hidden objects. Uneven terrain could overturn the machine. Tall grass can hide obstacles.
- Choose a low ground speed so that you will not have to stop while on the slope.
- Do not mow on wet grass. Tires may lose traction.
- Avoid starting, stopping, or turning on a slope. If the tires lose traction, disengage the blades and proceed slowly straight down the slope.
- Keep all movement on the slopes slow and gradual. Do not make sudden changes in speed or direction, which could cause the machine to roll over.
- Use extra care while operating machine with grass catchers or other attachments; they can affect the stability of the machine.
- Do not use on steep slopes.
- Do not mow near drop-offs, ditches, or embankments. The machine could suddenly roll over if a wheel is over the edge or if the edge caves in.

Safe Handling of Gasoline

To avoid personal injury or property damage, use extreme care in handling gasoline. Gasoline is extremely flammable and the vapors are explosive.



WARNING! The engine and the exhaust system become very hot during operation. There is risk for burns if touched. Allow engine and exhaust system to cool to a safe temperature before refueling.

- Never fuel the machine indoors.
- Before you begin refueling, minimize the risk of static electricity by touching a metal surface.

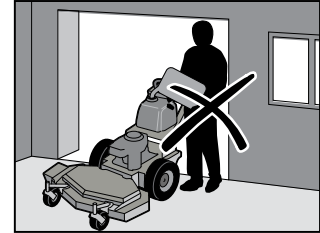

- Check the fuel level before each use and leave space for the fuel to expand, as the heat from the engine and the sun may otherwise cause the fuel to expand and overflow.
- Never remove gas cap or add fuel with the engine running. Allow engine to cool before refueling.
- Never overfill fuel tank. Replace gas cap and tighten securely.
- If fuel is spilled on clothing, change clothing immediately.
- Do not start the engine near spilled fuel.
- Extinguish all cigarettes, cigars, pipes, and other sources of ignition.
- Use only an approved fuel container. Use only non-metal, portable fuel containers approved by the Underwriter's Laboratory (UL) or the American Society for Testing & Materials (ASTM). If using a funnel, make sure it is plastic and has no screen or filter.
- Never fill containers inside a vehicle or on a truck or trailer bed with plastic liner. Always place containers on the ground away from the vehicle when filling.
- Remove gas-powered equipment from the truck or trailer and refuel it on the ground. If this is not possible, refuel such equipment with a portable container, rather than from a gasoline dispenser nozzle.

- Keep the nozzle in contact with the rim of the fuel tank or container opening at all times until fueling is complete. Do not use a nozzle lock-open device.
- If leaks arise in fuel system, engine must not be started until problem has been resolved.
- Never store the machine or fuel container where there is an open flame, spark, or pilot light such as on a water heater or other appliance.
- Do not use gas with methanol. Methanol is harmful to your health and to the environment.
- Do not modify safety equipment. Check regularly to be sure it works properly. The machine must not be used with defective or unmounted protective plates, protective cowlings, safety switches, or other protective devices.
- Do not change the settings of governors and avoid running the engine with overly high engine speeds. If you run the engine too fast, you risk damaging the machine components.
- Use protective goggles.
- Ensure that the fuel filler cap is mounted tightly and no flammable substances are stored in an open vessel.

General Maintenance

- Never use the machine indoors or in spaces lacking proper ventilation. The exhaust fumes contain carbon monoxide, an odorless, poisonous, and lethal gas.



- Keep all nuts and bolts tight to be sure the equipment is in safe working condition.
- Never tamper with safety devices. Check their proper operation regularly.
- Keep machine free of grass, leaves, or other debris buildup. Clean oil or fuel spillage and remove any fuel-soaked debris. Allow machine to cool before storing.
- If you strike a foreign object, stop and inspect the machine. Repair, if necessary, before restarting.
- Never make any adjustments or repairs with the engine running.
- Check the discharge guard frequently and replace with manufacturer's recommended parts, when necessary.
- Mower blades are sharp. Wrap the blade or wear gloves, and use extra caution when servicing them.
- Check brake operation frequently. Adjust and service as required.
- Maintain or replace safety and instruction labels, as necessary.
- Check wheel hardware tightness often during the first 100 hours of operation. Wheel hardware must be tightened to specified torque using the proper procedure anytime it is loosened.
- The machine is tested and approved only with the equipment originally provided or recommended by the manufacturer. Only use approved repair parts for the machine.
- Reduce the risk of fire by removing grass, leaves, and other debris that may have accumulated on the machine. Allow the machine to cool before putting it in storage.
- Hydraulic hoses and lines can fail due to physical damage, kinks, age, and exposure. Check hoses and lines regularly. Replace damaged hoses and lines.
- Hydraulic fluid connections can loosen due to physical damage and vibration. Check connections regularly. Tighten loose connections.
- Escaping fluid under pressure can penetrate the skin causing serious injury. Avoid the hazard by relieving pressure before disconnecting hydraulic or other lines. Tighten all connections before applying pressure.
- Search for leaks with a piece of cardboard. Protect hands and body from high pressure fluids.
- If an accident occurs, see a doctor immediately. Any fluid injected into the skin must be surgically removed within a few hours or gangrene may result. Doctors unfamiliar with this type of injury should reference a knowledgeable medical source.
- Always maintain the correct tire pressure. Do not inflate the tires above the recommended pressure. Never weld or heat a wheel and tire assembly. The heat can cause an increase in air pressure resulting in a tire explosion. Welding can structurally weaken or deform the wheel.

- When inflating tires, use a clip-on chuck and extension hose long enough to allow you to stand to one side and NOT in front of or over the tire assembly.
- Check tires for low pressure, cuts, bubbles, damaged rims or missing lug bolts and nuts.
- Regularly clean deck and underside of deck, avoid spraying engine and electrical components with water.

Waste Product and Chemicals

- Waste products, such as, used oil, fuel, coolant, brake fluid, and batteries, can harm the environment and people:
- Do not place waste fluids in used beverage containers.
- See your local Recycling Center or authorized dealer to learn how to recycle or get rid of waste products.
- A Material Safety Data Sheet (MSDS) provides specific details on chemical products: physical and health hazards, safety procedures, and emergency response techniques. The seller of the chemical products used with your machine is responsible for providing the MSDS for that product.

Transport

- The machine is heavy and can cause serious crushing injuries. Be extra cautious when it is loaded on or unloaded from a vehicle or trailer.
- Use an approved trailer to transport the machine. Activate the parking brake, turn off the fuel supply, and fasten the machine with approved fastening devices, such as bands, chains, or straps, when transporting.
- Check and abide by local traffic regulations before transporting the machine on any road.

Maintenance and Storage

- Never store the equipment with fuel in the tank inside a building where fumes might reach an open flame or spark. Allow the engine to cool before storing in any enclosure.
- If the fuel tank has to be drained for storage perform this task outdoors.
- Maintain or replace safety and instruction labels, as necessary.
- Clear debris from movable parts, but only when the power source is shut off. DO NOT spray water to clean unit.
- Check to be sure all nuts and bolts are tight to assure the equipment is in safe working condition.
- For extended storage, clean unit thoroughly. See engine manual for proper storage.

Spark Arrestor

The engine in this machine is not equipped with a spark arrestor muffler. It is a violation of California Public Resource Code Section 4442 to use or operate this engine on or near any unimproved forested, bush covered or grassy lands unless the exhaust system is equipped with a spark arrestor meeting any applicable local or state laws. Other states or federal areas may have similar laws. A spark arrestor for your machine may be available from your authorized dealer. An installed spark arrestor must be maintained in good working order by the operator.

ASSEMBLY

1. After removing the unit from shipping container, adjust tire pressure to 10 to 14 psi (70 to 95 kPa).
2. Check the adjustments outlined in *Maintenance*.
3. Check engine oil level. See the engine manual.
4. Add clean fuel to the fuel tank. See engine manual for type and grade.
5. Check for loose hardware.
6. Make sure that safety interlock system operates correctly. See *Safety Interlock System*.
7. Make sure that unit tracks straight. The unit must not pull sharply to the left or right when the steering levers are released. See *Tracking Adjustment*.



CAUTION! Avoid injury! Explosive separation of tire and rim parts is possible when they are serviced incorrectly.

- Do not attempt to mount a tire without the proper equipment and experience to perform the job.
- Do not inflate the tires above the recommended pressure.
- Do not weld or heat a wheel and tire assembly. Heat can cause an increase in air pressure resulting in an explosion. Welding can structurally weaken or deform the wheel.
- Do not stand in front or over the tire assembly when inflating. Use a clip-on chuck and extension hose long enough to allow you to stand to one side.

CONTROLS

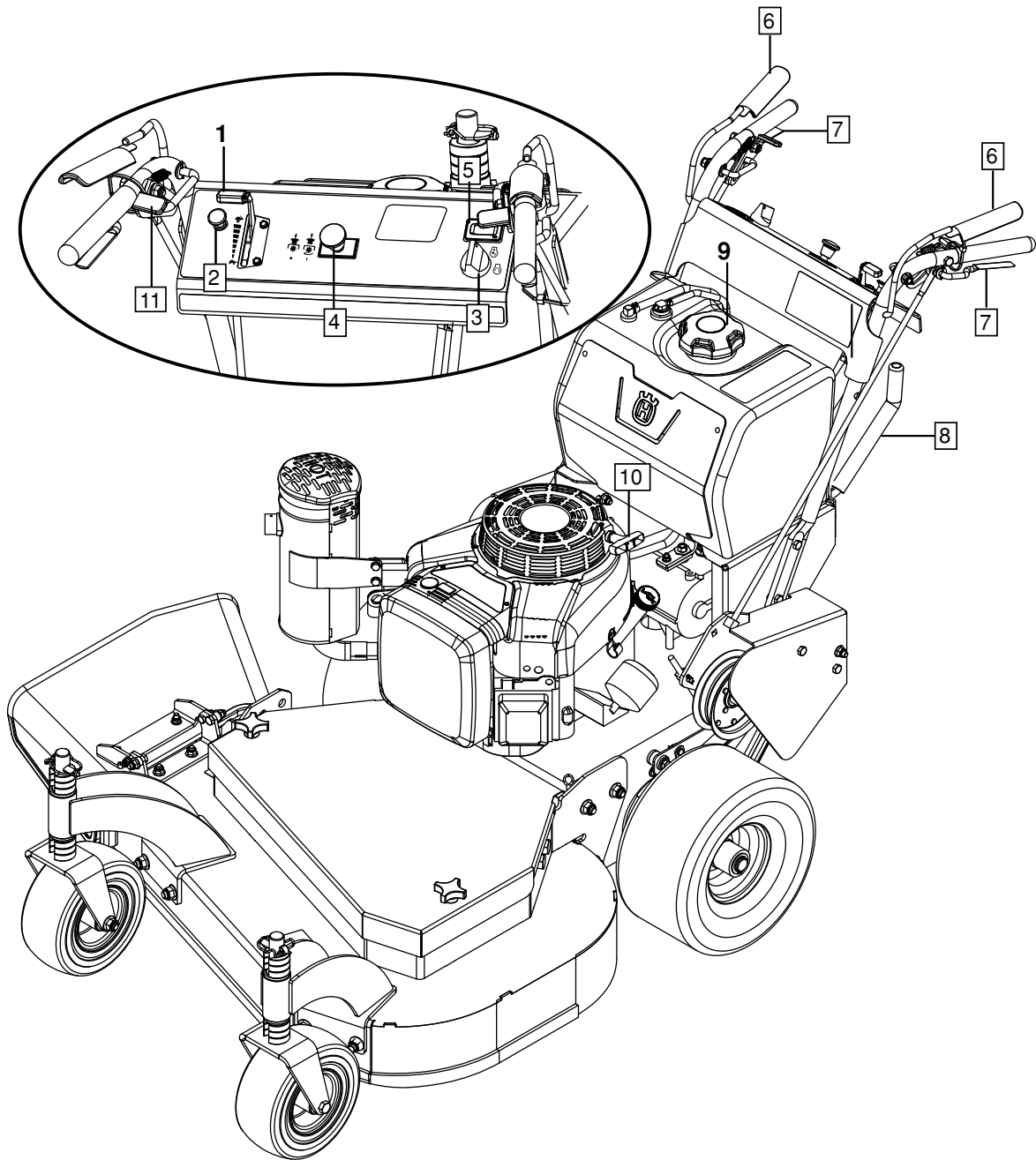

- | | |
|-----------------------------|--------------------------|
| 1. Throttle Control | 7. Steering Levers |
| 2. Choke Control | 8. Shift Lever |
| 3. Ignition Switch | 9. Fuel Cap/Tank |
| 4. PTO Switch | 10. Recoil Starter Grip |
| 5. Service Meter | 11. Steering Lever Latch |
| 6. Operator Presence Levers | |

OPERATION

 **WARNING!** Avoid injury. Read and understand the entire *Safety* section before proceeding.

Safety Interlock System

 **WARNING!** Safety interlock System failure and improper operation of unit can result in death or serious injury. **ALWAYS** know the safety interlock system is operating properly.

Test the safety interlock system before each operation. If the system does not function properly, do not operate the unit until repairs are made.

The engine will only start with the PTO disengaged. The shift lever must be in neutral for engine to start.

The engine must not start unless PTO is disengaged and the shift lever is in neutral.

Testing

1. With engine off, engage PTO.
2. Turn ignition switch to OM. Pull recoil start handle. Engine must not start.
3. Disengage PTO.

Operator Presence Control

The operator presence control lever must be pressed to operate the PTO. When the shift lever or PTO is engaged, releasing the operator presence control lever stops the engine.

The engine **MUST** stop whenever the operator removes both hands from controls while the PTO or transmission is engaged.

Testing

1. Start engine and engage PTO.
2. Release operator presence control lever(s). Engine must stop.
3. Disengage PTO.
4. Restart engine.
5. Place shift lever in Forward.
6. Release operator presence control lever. Engine must stop.

Steering Levers

 **WARNING!** Avoid injury! When the engine is running and the shift lever is engaged, releasing only one steering latch causes the unit to circle around one drive wheel.

ALWAYS hold both steering levers against the handlebar when releasing the steering lever latches. **ALWAYS** release levers slowly.

The steering levers are used to steer, operate in forward and reverse, and stop the unit. When held against the handlebar, the brakes are engaged.

Steering Lever Latches

The steering lever latches hold the steering levers in the neutral position and keep the brakes applied.

Ignition Switch

Operate the ignition switch with the removable ignition key. To start the engine, turn the ignition key to the start position.



When the engine starts, release the ignition key back to the run position.



Pull the recoil handle.

To stop the engine, turn the ignition key to OFF.



Throttle Control

The throttle lever changes the speed of the engine. Move the throttle lever to *FAST* (rabbit) to increase engine speed. Move the lever to *SLOW* (turtle) to decrease engine speed.

Operator Presence Levers

The operator presence control lever must be pressed to operate the PTO or traction drive. When the shift lever or PTO is engaged, releasing the operator presence control lever stops the engine.

Choke Control

Use the choke control to start a cold engine. Pull the control out to choke the engine. Push the control in when the engine gets warm.

Shift Lever

The shift lever sets the direction and speed of the unit.

R = Reverse

N = Neutral



= the slowest forward speed

= the fastest forward speed.

PTO Clutch

Pull the PTO (power take off) switch UP to engage the mower blades.

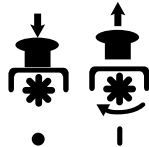

Push the PTO switch DOWN to disengage the mower blades.

Service Meter

Measures the number of hours the engine has been run.

Recoil Starter Grip

Pull the recoil starter handle to start the engine.



WARNING! Fuel is highly flammable and its vapors are explosive. Handle with care. Use an approved fuel container.

NO smoking, NO sparks, NO flames. ALWAYS allow engine to cool before servicing. NEVER fill fuel tank when engine is running or hot from operation. NEVER fill or drain fuel tank indoors. Replace fuel cap securely and clean up spilled fuel.

Fuel Tank

Use regular grade unleaded fuel with an octane rating of 87 octane or higher. Fuel blends containing up to 10% ethanol or up to 15% MTBE reformulated fuel are acceptable. Do not use fuel or additives containing methanol as engine damage can occur.

Always use fresh, clean fuel that is purchased in a quantity that can be used within approximately 30 days, or add fuel stabilizer.

Fuel is blended to give best seasonal performance. To avoid engine performance problems such as hard starting or vapor lock, use in-season fuel. Use fuel during warm weather that was purchased during that season, and use fuel during cold weather that was purchased during that season.

Fuel can become stale in machines with engines that are used seasonally or infrequently during a season. Stale fuel can produce varnish and plug carburetor components which can affect engine performance.

Keep fuel storage container tightly covered and in a cool area out of direct sunlight. Fuel can break down and degrade if not sealed properly or exposed to sun and heat.

Condensation may collect in the fuel tank because of a variety of operating or environmental conditions and, over time, may affect your machine's operation. Fill fuel tank at the end of daily use and store fuel in plastic containers to reduce condensation.

For best year-round performance and fuel handling, add stabilizer to fuel immediately after fuel purchase. Such practice helps prevent engine performance problems and allows fuel storage in the machine all year without draining.

Adding fuel

1. Move the unit to an open area.
2. Stop the engine and allow engine to cool.
3. Clean the fuel cap and the area around the fuel cap to prevent dirt from entering the fuel tank.
4. Remove the cap from the fuel tank and fill the fuel tank. Do not overfill. Avoid spills.
5. Reinstall the cap on the fuel tank and tighten.
6. Clean up any spilled fuel before starting the engine.

Emergency Stops

1. Release operator presence control(s).
2. Turn the ignition key Off.
3. Allow engine to stop completely.
4. Lock steering levers in neutral.

Starting And Shut Off

Before each use check the **Maintenance Schedule**.

NOTE: The engine will not start unless the shift lever is in neutral, and the PTO is OFF.

Recoil Start

1. Lock the steering lever latches in neutral.
2. Put the shift lever in neutral.
3. Move PTO switch to *OFF*.
4. Set throttle to the proper starting position. If the engine is cold, choke the engine.
5. Turn ignition switch to *ON*.
6. Grasp recoil starter handle and pull rope out slowly until it pulls harder. This is the compression stroke.
7. Let the rope rewind slowly.
8. Pull rope with rapid continuous full arm stroke to start engine. Allow rope to rewind slowly.

IMPORTANT DO NOT let starter handle snap against engine.

9. Repeat until engine starts. (If engine does not start, refer to Engine Manual.)
10. After engine starts, adjust choke as needed. Allow engine to warm and run smoothly before operating unit.

Shut Off

1. Lock steering levers in neutral.
2. Shut off the PTO.
3. Move the throttle lever to Slow.
4. Put the shift lever in neutral.
5. Turn the ignition key *OFF*.
6. Allow engine to stop completely.

Operating the Unit

Use the unit only in the operator's position directly behind the controls.

Shifting

Stop unit movement by pulling both steering levers all the way up.

IMPORTANT To prevent damage to the unit, always disengage the drive and come to a complete stop before changing gears.

Move the shift lever:

Continue to hold up both steering levers and use a knee to move the shift lever to the desired position.

or

Lock both steering levers. Move the shift lever to the desired position. Hold the steering levers up and unlock them.

Release both steering levers slowly.



WARNING! Avoid injury. When the engine is running and the shift lever is engaged, releasing only one steering latch causes the unit to circle around one drive wheel. ALWAYS hold both steering levers against the handlebar when releasing the steering lever latches. ALWAYS release levers slowly.

Operation

1. Start the engine.
2. Move the throttle lever to the *FAST* position.
3. Engage the operator presence control and move shift lever to desired direction and speed.
4. Hold steering levers against the handlebar and release steering lever latches.
5. Hold steering levers in neutral and release steering latch levers.
 - To move straight forward; slowly release both steering levers to the full outward position.



- To stop unit in neutral, hold levers in the neutral position.



- To lock unit in neutral, engage both steering latches.

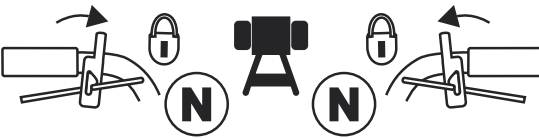

- To turn to the left, pull the left hand lever up.

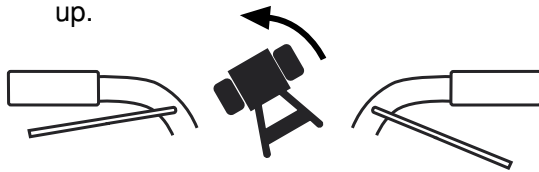

- To turn to the right, pull the right hand lever up.

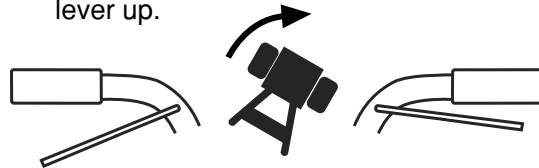

- To move in reverse, pull both steering levers up, past the neutral position. Pulling the levers farther up increases reverse speed.



6. To move in reverse:
 - Hold the steering levers against the handlebar.
 - Engage steering lever latches.
 - Engage the operator presence control and move shift lever to Reverse.
 - Release steering levers slowly.

Mowing

1. Lock steering levers in neutral.
2. Put the shift lever in neutral.
3. Move the throttle lever to the fast position.
4. Engage the operator presence control lever.
NOTE: Operator presence control must remain engaged.
5. Move the PTO switch to On to engage mower.
6. Move the shift lever to set a slow ground speed.

IMPORTANT To prevent damage to the PTO belt, do not engage the PTO if the mower is plugged with grass or other material.

7. Hold steering levers against the handlebar and release the lock latches.
8. Release steering levers slowly.
9. When you know how to operate the unit, select a speed appropriate to your mowing conditions.

Stop Mowing

1. Lock the steering levers in neutral.
2. Keep one hand on the operator presence control and move the shift lever to the neutral position.
3. Move the throttle lever to speed.
4. Turn off PTO switch.

Cutting Height Adjustment

WARNING! ALWAYS block wheels, engage parking brake and know all jack stands are strong, secure and able to hold weight of unit during maintenance.

Adjust the cutting height using a combination of the mounting location on the deck carrier frame, spacers on the front casters and spacers between the mower blades and the deck spindles. The desired cutting height may be set by adjusting only the blade spacers and caster spacers.

Refer to the cutting height charts below to determine which combination of location and spacers will set the desired cutting height.

1. Support the rear of the machine and the back edge of the mower deck.
2. Remove the six deck mounting bolts (three per side, lower bolt not shown).

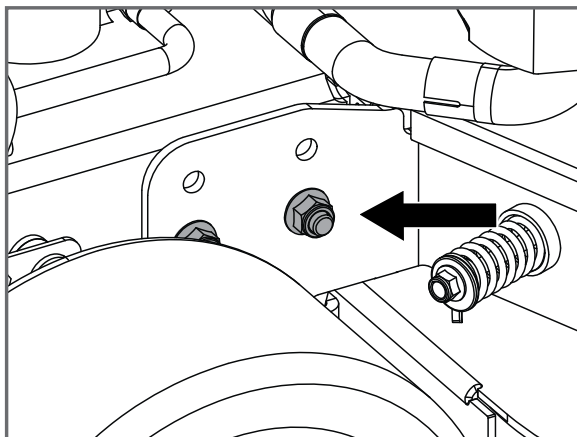

3. Align the mounting holes in the deck frame with the unit frame and reinstall the mounting bolts in the appropriate holes and tighten to 35 –40 lbf-ft (47– 54 N•m).

IMPORTANT To prevent damage to the unit, always disengage the drive and come to a complete stop before changing gears.

4. Using a suitable lifting device, lift the front of the machine.
5. Remove pin and spacer bushing.

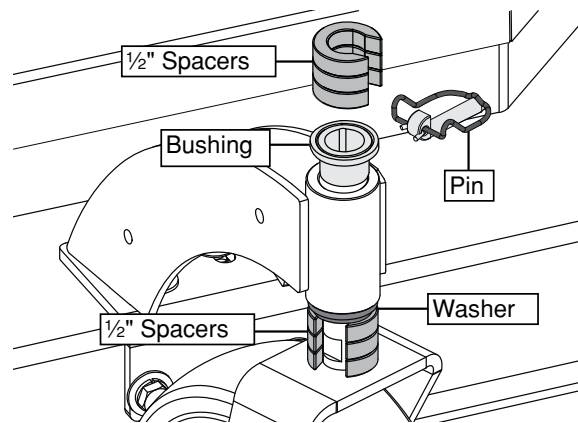

IMPORTANT The washer must always be installed on top the lower HOC spacers.

6. Adjust caster wheel spacers to set the front cutting height accordingly.
7. Remove the mower blade from the spindle and place the appropriate number of 1/4" spacers (washers) between the spindle and the blade.

NOTE: If two or three spacers are removed, shorter blade bolts must be used. The bolts for this application are mounted under the belt cover.



CAUTION! Blades are sharp. Protect your hands with gloves and/or wrap blades with a heavy cloth when handling. On multi-blade mowers, rotation of one blade will cause all blades to rotate.

IMPORTANT DO NOT allow the blade to be less than 1/8" (3.2 mm) above the lip of the mower deck.

8. Replace mower blade and tighten blade bolt to 120 lbf-ft (163 N•m).
9. Remove supports from deck and mower frame.

NOTE: Store the unused 1/4" spacers on hex bolts mounted on the rear of the deck.

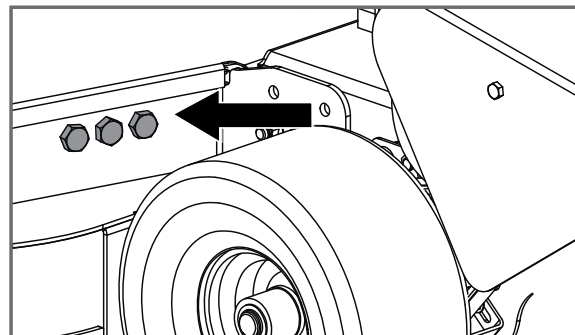

Cutting Height Chart - Deck bolted to frame -top holes

Cutting Height		¼" Blade Spacers		½" Caster Spacers	
In.	Cm.	Stored	Between Spindle and Blade	Below Weldment	Above Weldment
1¼	3.2	0	3	0	6
1½	3.8	1	2	0	6
1¾	4.4	2	1	0	6
2	5.1	3	0	0	6
1½	3.8	0	3	1	5
1¾	4.4	1	2	1	5
2	5.1	2	1	1	5
2¼	5.7	3	0	1	5
1¾	4.4	0	3	2	4
2	5.1	1	2	2	4
2¼	5.7	2	1	2	4
2½	6.35	3	0	2	4
2	5.1	0	3	3	3
2¼	5.7	1	2	3	3
2½	6.35	2	1	3	3
2¾	7.0	3	0	3	3

Recommended range for best cut quality

Cutting Height Chart - Deck bolted to frame -bottom holes

Cutting Height		¼" Blade Spacers		½" Caster Spacers	
In.	Cm.	Stored	Between Spindle and Blade	Below Weldment	Above Weldment
2¾	7.0	0	3	3	3
3	7.62	1	2	3	3
3¼	8.3	2	1	3	3
3½	8.9	3	0	3	3
3	7.62	0	3	4	2
3¼	8.3	1	2	4	2
3½	8.9	2	1	4	2
3¾	9.5	3	0	4	2
3¼	8.3	0	3	5	1
3½	8.9	1	2	5	1
3¾	9.5	2	1	5	1
4	10.2	3	0	5	1
3½	8.9	0	3	6	0
3¾	9.5	1	2	6	0
4	10.2	2	1	6	0
4¼	10.8	3	0	6	0

Recommended range for best cut quality

Parking

1. Shut off the unit. See **Shut Off** and **Stop Mowing**.
2. Remove the ignition key.
3. Lock both steering lever latches in neutral to engage the brakes.
4. Chock or block the wheels if parked on a slope.

Pushing unit by hand

To move the unit without the engine running:

1. Put the shift lever in neutral.
2. Disengage the lock latches. Release steering levers. The brake is disengaged when the steering levers are released.
3. Push unit to desired location.

IMPORTANT Towing the unit will damage transmission.

Trailer Transporting



CAUTION! Avoid damage!
Transporting a machine on a trailer or on a truck bed at high speeds can result in hood or engine cover raising and possibly coming off machine if not secured.

Use a heavy-duty trailer to transport your machine. Trailer must have signs and lights required by law.

1. Position machine on trailer so the hood or engine cover opens from rear of trailer, preventing wind from blowing hood or cover open.
2. Secure hood or engine cover with existing machine locks or latches.
3. Secure hood or engine cover with tie down straps if no locks or latches exist.
4. Drive machine onto a trailer.
5. Engage brake lever locks.
6. Place transmission in NEUTRAL.
7. Shut engine off and remove ignition key.
8. Turn fuel shutoff valve to OFF position.
9. Fasten machine to trailer with heavy duty straps, chains or cables. Both front and rear straps must be directed down and outward from machine.



CAUTION! Avoid injury! Use extra care when loading or unloading the machine into a trailer or truck. Close fuel shut-off valve, if your machine is equipped.

MAINTENANCE SCHEDULE

MAINTENANCE	Before Use	Maintenance interval in hours		
		25	50	100
Perform the Safety Interlock System Check. ¹⁾	●			
Check the engine's oil level. Do not operate with low oil level.	■			
Check/clean the engine's air cleaner.	■			
Check/clean the engine's cooling air intake.	■			
Check for fuel and oil leakages.	◆			
Check all nuts, bolts, and other fasteners. Replace if needed.	◆			
Check tires for proper inflation (10-14 PSI, 70-95 kPa), excessive wear or damage	◆			
Perform Engine Manual Maintenance Schedule	■			
Check belts and tension for wear, damage or slippage.		◆		
Check, sharpen or replace mower blades		●		
Clean the foam air cleaner filter		■		
Oil all pivot points, pin connections. Grease lube fittings			●	
Change engine oil ²⁾				■
Check spark plug				■
Check muffler for wear or damage. Replace if needed.				■
Clean the paper air cleaner filter				■

¹⁾ A Safety Interlock System failure or improper operation of unit can result in death or serious injury. Test each time the unit is operated. If it does not function as described, do not operate until repairs are made.

²⁾ First change after 8 hours and every 100 hours thereafter.

- = Described in this manual
- ◆ = Not described in this manual
- = Refer to the Engine Manual

MAINTENANCE



WARNING! Avoid injury. Read and understand the entire Safety section before proceeding.

General Lubrication

Apply a small amount of oil to the pivot points as required for smooth operation. Apply high quality lithium based grease to all lube fittings every 50 hours of operation (spindle bearings every 160 hours).

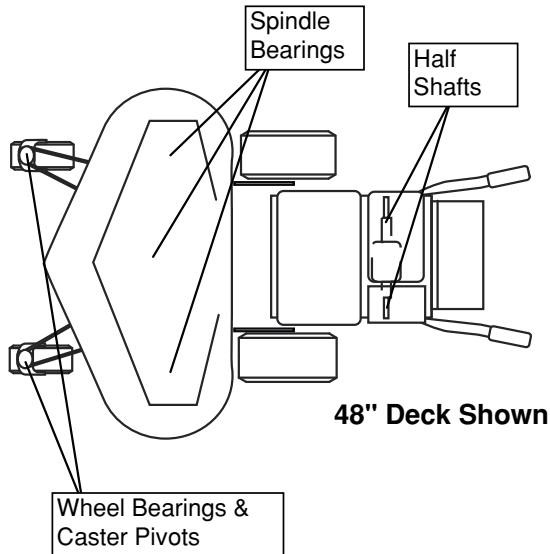

Tracking Adjustment

Check Forward Tracking

1. Start engine and run unit at full throttle.
2. Shift into a forward gear and slowly release both steering levers to the full outward position.
3. Note to which direction, if any, the unit pulls.
4. Stop unit and engine.
5. Adjust tracking if needed.

Try each of the following steps until the unit tracks straight. It may not be necessary to perform all the steps.

If unit turns to the right:

1. Reduce the air pressure in the left tire.
2. Increase the air pressure in the right tire.
3. Check for brake binding on right wheel and adjust as needed.

If unit turns to the left:

1. Reduce the air pressure in the right tire.
2. Increase the air pressure in the left tire.
3. Check for brake binding on left wheel and adjust as needed.

Adjusting Steering Levers

For each lever:

1. Turn off the engine, remove the ignition key and allow unit to cool.
2. Release steering or control levers.
3. Shift transmission into neutral. Operate steering or control lever several times. Do not move unit.
4. Remove the hair pin and disconnect the trunnion from the wheel clutch.
5. Adjust the trunnion on the steering control rod until the gap between the ends of the steering lever and handlebar grip is 3 to 3 1/4". (7.62 – 8.26 cm).
6. Reconnect trunnion to wheel clutch and secure with hair pin.
7. Repeat for other steering lever.

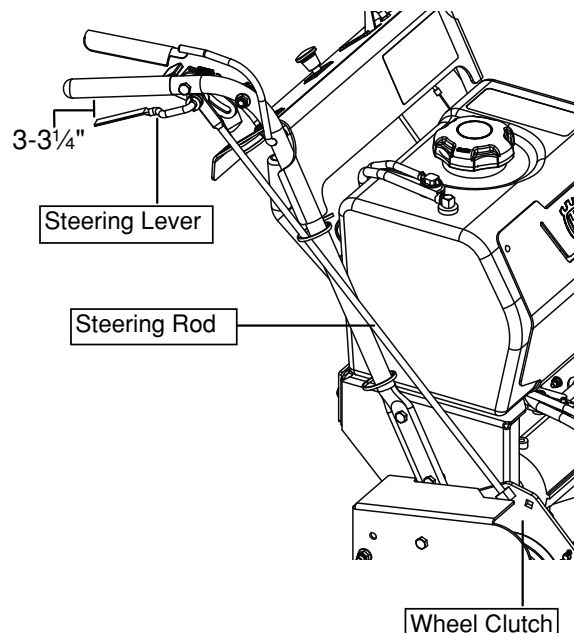

Adjusting Brakes

NOTE: The traction belt must disengage as the brake starts to engage.

1. Turn off the engine, remove the ignition key and allow unit to cool.
2. If brakes do not disengage fully when traction belt is engaged, the brakes are too tight. Disconnect trunnion from the clutch weldment and turn the trunnion up the brake rod to reduce braking. Reconnect the trunnion to the clutch weldment.

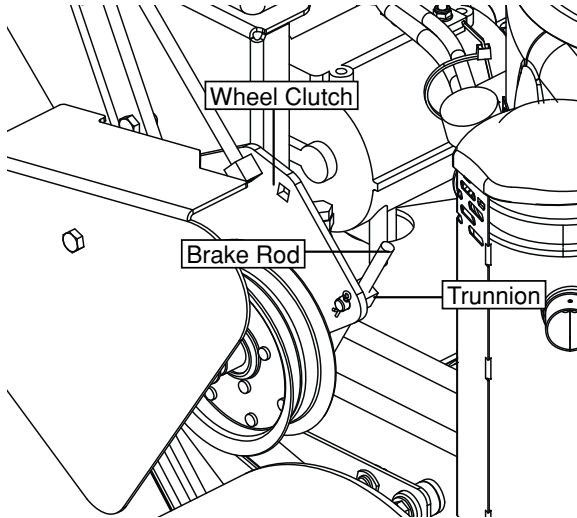

3. If brakes do not engage fully when traction belt is disengaged, the brakes are too loose. Disconnect trunnion from the clutch weldment and turn the trunnion down the brake rod to increase braking. Reconnect the trunnion to the clutch weldment.
4. Start engine and test in low gear for proper brake engagement.

Replacing Traction Belts

1. Turn off the engine, remove the ignition key and allow unit to cool.
2. Release the steering levers.
3. Raise the rear of the unit so that the drive wheels are off the ground. Make sure the unit is securely supported.
4. Disconnect clutch idler pulley spring.
5. Remove traction belt guard.
6. Remove hair pin and trunnion holding steering control rod to wheel clutch weldment.
7. While slowly turning the drive wheel, work the traction belt off the transmission shaft pulley and drive wheel.
8. Install new traction belt.
9. Connect steering control rod to wheel clutch arm weldment with trunnion and hair pin.

10. Replace traction belt guard.
11. Replace clutch idler pulley spring.
12. Lower the unit.
13. Check steering lever adjustment.



WARNING! Avoid injury. An extension spring can be dangerous. Always use tools specifically designed for installing or removing an these springs. Always compress or extend springs slowly.

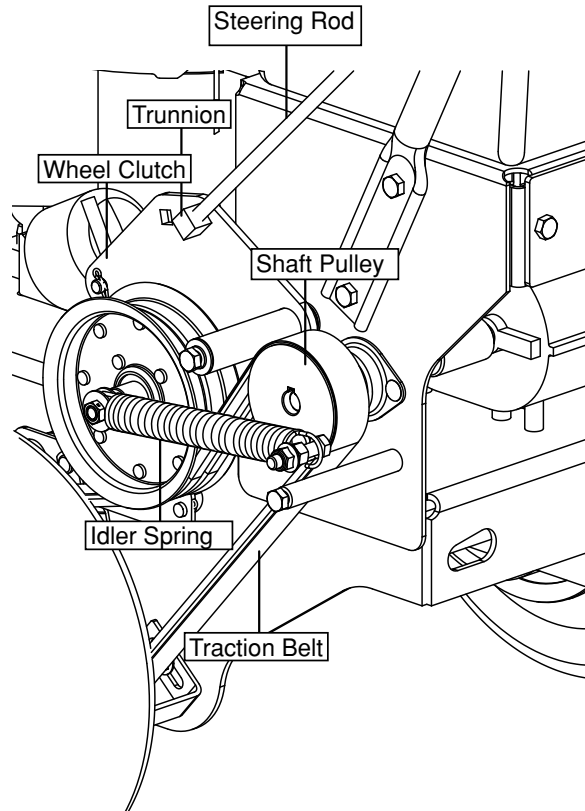

Adjusting Shift Lever Linkage

IMPORTANT If the shift lever and the transmission detent are improperly aligned, the transmission may fail prematurely. Align the shift lever and detent as carefully as possible. The .030 (.8 mm) clearance helps prevent premature wear of the detent plate and shift lever.

The transmission shift lever is attached to the transmission shift arm with two $\frac{5}{16}$ -18 bolts.

Adjusting:

1. Stop the engine and remove ignition key. Put PTO lever in the OFF position. Put the shift lever in neutral.
2. Loosen the two bolts on shift lever.

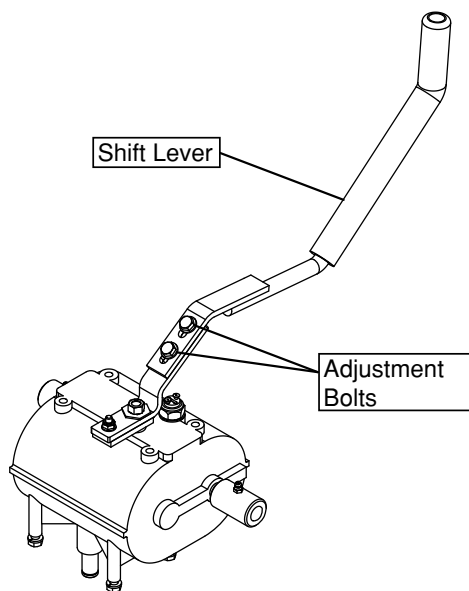

3. Align the shift lever so it is centered in gear Position 2 on the detent plate and is .030 in. (.8 mm) from the V.

NOTE: If the shift lever cannot be adjusted to tolerance with the shift lever hardware alone, loosen the hardware holding the detent plate to the frame and adjust the detent plate to tolerance.

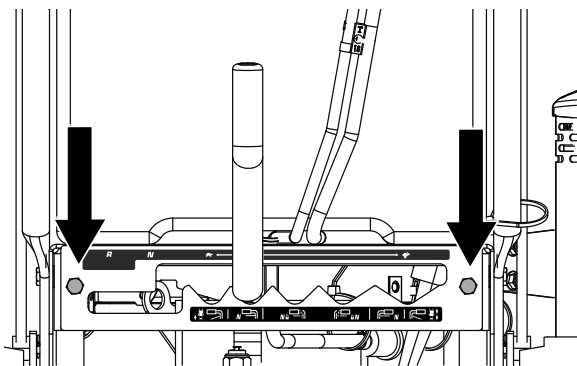

4. Tighten bolts securely.
NOTE: Before starting unit, test the shift lever to make sure it engages all gear positions.

Replacing Transmission Belt

1. Stop the engine and remove ignition key. Put PTO lever in the OFF position. Put the shift lever in neutral.

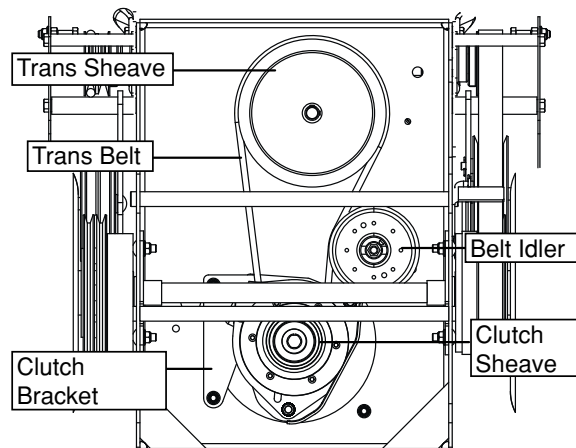

2. Remove mower drive belt from mower clutch sheave.
3. Loosen idler pulley mounting bolt and slide idler pulley away from the belt.
4. Loosen one and remove one engine mounting bolt and turn the clutch stop away from the clutch. Save the hardware.
5. Remove old transmission belt from mower clutch sheave and transmission sheave.
6. Install new belt in the top groove of the clutch hub and on the transmission sheave.
7. Slide idler pulley to the belt to tension it, and then tighten the mounting bolt to hold the position.
8. Reposition clutch stop, replace engine bolt, and torque both engine bolts to 17 lbf-ft (23 N•m).
9. Reinstall mower drive belt on mower clutch sheave.

Belt Replacement 36"

1. Turn off the engine, remove the ignition key and allow unit to cool.
2. Remove deck cover.
3. Turn the idler spring adjusting nut to relieve tension from the idler spring.
4. Remove belt from deck sheaves and mower clutch sheave.
5. Install new belt.
6. Tighten the adjusting nut to tension the belt. Tighten the nut until the idler spring compresses to 2 in. \pm 1/8 in. (5.1 cm \pm .32 cm). See Figure 16.
7. Replace deck cover and secure.

Belt Replacement 48"

Deck Belt

1. Turn off the engine, remove the ignition key and allow unit to cool.
2. Remove deck cover.
3. Turn the deck belt idler spring adjusting nut to relieve tension from the idler spring.
4. Remove deck belt from deck sheaves.

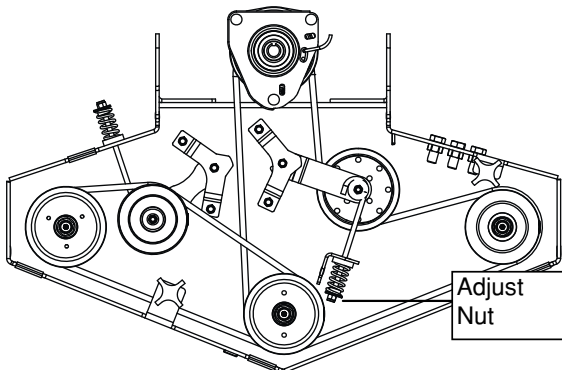

5. Install new deck belt.
6. Tighten the adjusting nut to tension the belt. Tighten the nut until the idler spring compresses to 2 in. \pm 1/8 in. (5.1 cm \pm .32 cm).
7. Replace deck cover.

Mower Drive Belt

NOTE: Deck belt must be removed before removing the mower drive belt.

1. Turn off the engine, remove the ignition key and allow unit to cool.
2. Remove deck cover.
3. Remove deck belt.
4. Turn the mower drive belt idler spring adjusting nut to relieve tension from the idler spring.

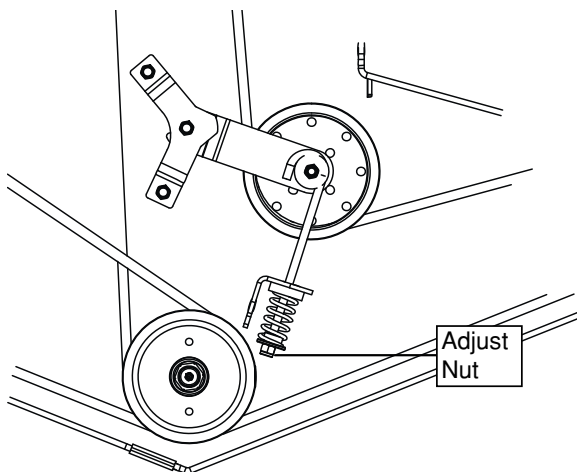

5. Remove mower drive belt from deck sheaves and mower clutch sheave.
6. Install new mower drive belt on deck sheaves and mower clutch sheave.
7. Tighten the adjusting nut to tension the belt. Tighten the nut until the idler spring compresses to 2 in. \pm 1/8 in. (5.1 cm \pm .32 cm).
8. Replace deck belt.
9. Replace deck cover and secure.
NOTE: Make sure wing knobs do not interfere with cutting height adjustments.

Mower Blades



CAUTION! Blades are sharp. Protect your hands with gloves and/or wrap blades with a heavy cloth when handling. On multi-blade mowers, rotation of one blade will cause all blades to rotate.

Blade Removal

1. Turn off the engine, remove the ignition key and the ignition wire from the spark plugs.
2. Block the blades with a wooden block to prevent blade rotation.
3. Remove the bolts, blades and spacers (number of spacers will vary depending on cutting height) from the spindle shafts.

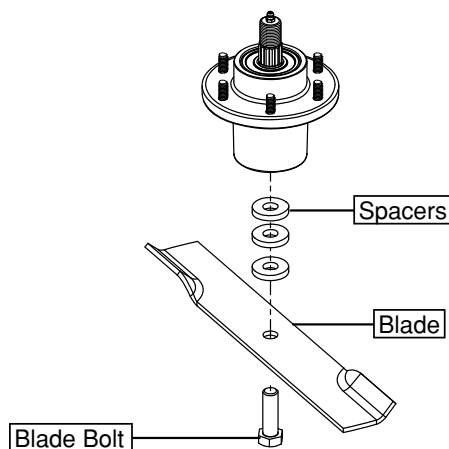

Blade Sharpening

1. Discard mower blade if:
 - More than ½" (1.27 cm) of metal is removed.
 - Air lifts become eroded.
 - Blade is bent or broken.
2. Sharpen mower blade by removing an equal amount of material from each end of mower blade. DO NOT change angle of cutting edge or round the corner of the mower blade.

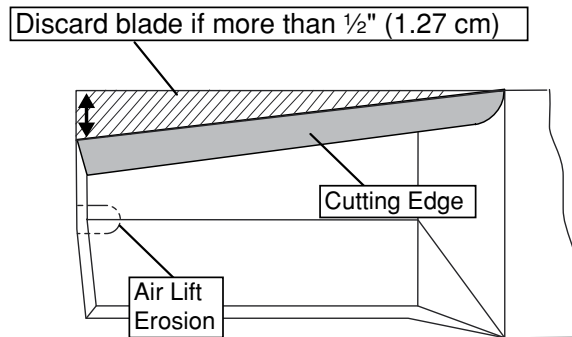
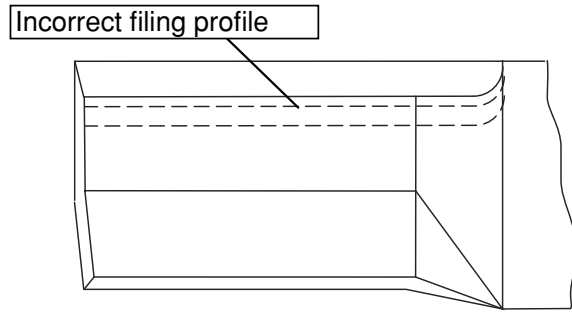

NOTE: If mower is used under sandy soil conditions, replace blades when air lifts become eroded through at ends.

3. Check mower blade balance. Slide mower blade on an unthreaded bolt. A balanced blade should remain in a horizontal position. If either end of mower blade moves downward, sharpen the heavy end until blade is balanced.
4. Reinstall the blade(s).

Replace Mower Blades

1. Reinstall the spacers, blades, and bolts on the spindle shafts.
2. Block blades with a wooden block to prevent blade rotation.
3. Tighten each blade bolt to a torque of 120 lbf-ft (163 N•m).
4. Replace ignition wire on spark plugs.

Replacing Mower Spindle Bearings

1. Turn the engine off. Remove the ignition key. Remove the ignition wire from the spark plugs.
2. Remove mower blade.
3. Remove nut, flat washer, spacer and pulley.
4. Remove spindle shaft, lower bearing and spacer from spindle housing. Discard bearing.
5. Remove and discard upper bearing.
6. Clean entire assembly.
7. Install a new lower bearing and spacer on the spindle shaft.

IMPORTANT Avoid damage! The clearance between the lower bearing and the housing is only .002 in (.05 mm). Do not force bearing into housing.

8. Install the spindle shaft, lower bearing and spacer into the spindle housing.
9. Install the upper bearing.
10. Install spacer.
11. Install pulley and nut. Tighten nut to 85 lbf-ft (115 N•m).
12. Grease the spindle. See *General Lubrication*.
13. Install mower blade, blade washers and blade bolt assembly. Tighten bolt to 120 lbf-ft (163 N•m).

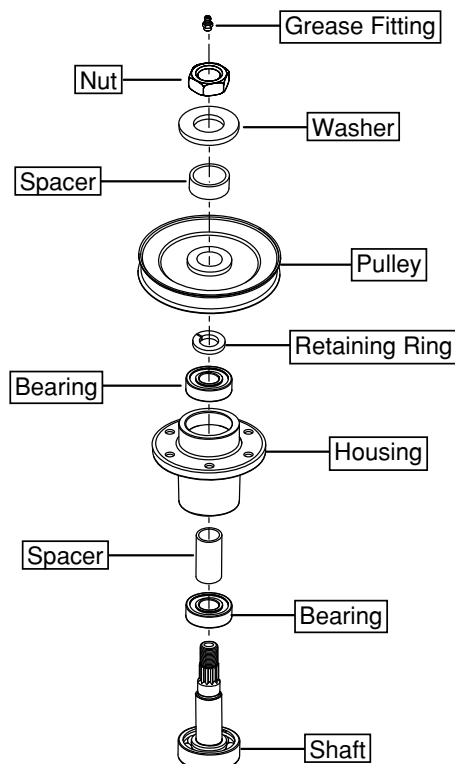

Replacing Caster Pivot Bearing Bushings

1. Turn the engine off. Remove the ignition key. Remove the ignition wire from the spark plugs.
2. Raise and securely support the front of the mower deck.
3. Remove lynch pin, spacer bushings, washer and caster yoke and wheel assembly.
4. Remove and discard upper and lower bushings.
5. Install new bushings.

IMPORTANT Do not allow washer to sit on caster yoke. It must be on top of the height-of-cut spacer bushings

6. Install caster yoke and wheel assembly, washer, spacer bushings and lynch pin.
7. Apply grease to grease fitting.

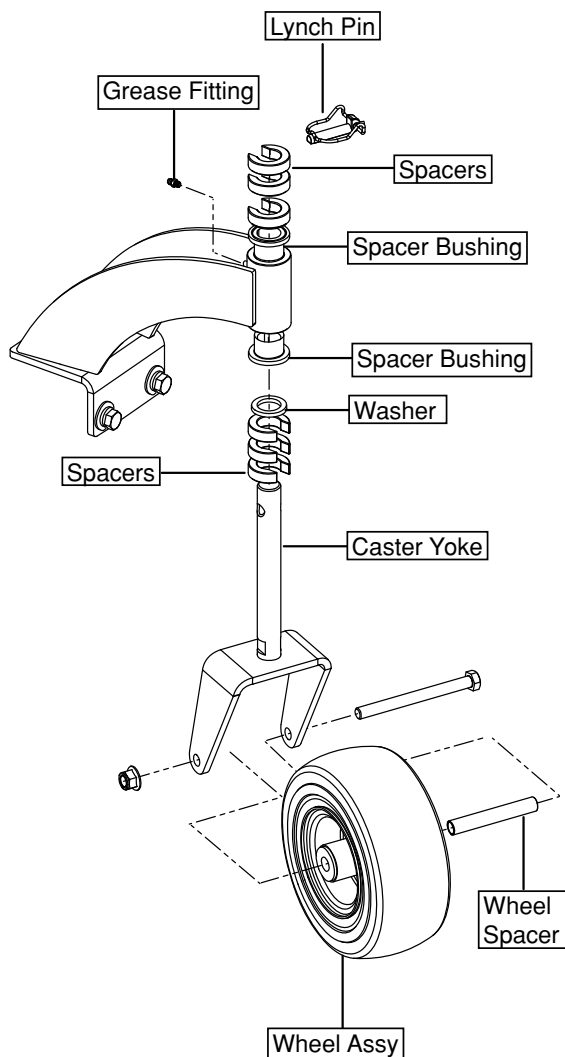

Electrical Service Replacing Fuse

IMPORTANT Avoid damage! When replacing fuses use only 25-amp fuses to avoid damage to the circuit.

The machine is equipped with one 25-amp fuse to protect the charging circuit. This fuse is located on the main harness, near the engine ground. Replace with an automotive type 25-amp fuse.

1. Remove defective fuse from socket.
2. Check metal clip in fuse window and discard fuse if clip is broken.
3. Install new fuse into socket.

STORAGE



WARNING! Avoid injury. Read and understand the entire Safety section before proceeding.

Storage for Two Months or More

1. Check each item in the *Maintenance Schedule*, but do not add gasoline.
2. Clean the unit. Touch up all scratched painted surfaces.

IMPORTANT Never spray unit with high pressure water or store unit outdoors. Store unit in a cool, dry, protected location.

3. Clean unit thoroughly with mild soap and low pressure water and lubricate (see *General Lubrication*).
4. Do not allow gasoline or oil to remain on any decals.

Engine

Refer to the engine manual to prepare the engine for storage.

Fuel System

Gasoline left in the fuel system for extended periods without a stabilizer will deteriorate, resulting in gum deposits in the system. These deposits can damage the carburetor and the fuel hoses, filter and tank. Prevent deposits from forming in the fuel system during storage by adding a quality fuel stabilizer to the fuel. Follow the recommended mix ratio found on the fuel stabilizer container.

To treat the fuel system for storage:

1. Add fuel stabilizer according to manufacturers' instructions.
2. Run engine for at least 10 minutes after adding stabilizer to allow it to reach the carburetor.

NEVER store the engine with fuel in the fuel tank inside of a building with potential sources of ignition.

TROUBLESHOOTING

Problem	Probable Cause	Correction
Engine will not start	<p>Safety Interlock System is preventing start</p> <p>Fuel tank empty or fuel is contaminated</p> <p>Air cleaner is clogged or damaged.</p> <p>Safety Interlock System out of adjustment or defective.</p> <p>Dirty or faulty spark plug</p>	<p>Make sure the shift lever is in neutral, the ignition key is in the ON position, and the Power Take Off is OFF</p> <p>Add fuel or replace with clean, fresh fuel</p> <p>Clean or replace the filter element see engine manual</p> <p>See dealer for repairs</p> <p>See engine manual</p>
Unit will not move or mow with engine running	Transmission belt or mower belt is broken, worn, or off the pulleys.	Check belts for wear, damage and correct position on pulleys. Replace belts if worn or damaged. See <i>Replacing Transmission Belt</i>
<p>Changes in the sound or vibrations of the unit</p> <p>Unit does not straighten immediately when the steering levers are released</p>	<p>Loose or missing fasteners</p> <p>Mower blade problem</p> <p>Worn or damaged clutch</p> <p>Steering levers out of adjustment</p>	<p>Check all the fasteners. Tighten or replace as necessary.</p> <p>Check blades for wear or damage. See <i>Mower Blades</i></p> <p>See dealer for repairs</p> <p>See <i>Adjusting Steering Levers</i></p>
Erratic movement of cylinder	Air in hydraulic system	Purge air from hydraulic system
Unit loses power	<p>Binding in the steering or brake linkage</p> <p>Steering levers out of adjustment</p> <p>Worn or damaged traction belts</p> <p>Traction belt slipping</p> <p>Transmission shaft pulley worn</p>	<p>Check linkage for debris or damage. Repair if necessary. See <i>Adjusting Brakes</i> or dealer for repairs</p> <p>See <i>Adjusting Steering Levers</i></p> <p>Check belts for wear or damage. Replace if necessary. See <i>Replacing Traction Belts</i></p> <p>Move the traction belt idler spring anchor to the rear most position. See <i>Replacing Traction Belts</i></p> <p>Check pulley for excessive wear, replace if necessary. See your Dealer for repairs</p>

SPECIFICATIONS

Model Number	W436	W448
Model	967334301-00	967334401-00
Engine		
Brand	Briggs & Stratton	
Engine Model	Vanguard 3567 18 HP	
Governed RPM (May be different from maximum RPM)	3600±100	
Cooling Capacity	Air cooled	
Speed		
Forward Maximum – mph (km/h)	5.4 (8.7)	
Reverse Maximum – mph (km/h)	Reverse Assist	
Turning Radius	0	
Brakes	6-Inch Band	
Electrical		
Starter	Recoil	
Power Take-Off	Electric PTO Clutch	
Fuel		
Fuel Type	Refer to engine manual	
Tank Capacity – gal. (L)	5.8 (22)	
Transmission		
Type	Peerless 5-Speed + Reverse	
Size and Weight		
Length – in. (cm)	75.6 (192)	70.9 (180)
Width – in. (cm)	48.4 (122.9)	60.8 (154.4)
Height – in. (cm)	41.9 (106.4)	41.9 (106.4)
Weight – lbs (kg)	464 (210.5)	530 (240.4)
Tires		
Rear Tire	13 x 5 4-Ply Rating	
Front Tire	9 x 3.5-4 Flat Free	
Tire Pressure – psi (kPa)	8 -16 (55 – 110)	
Mower Deck		
Cutting Width – in. (cm)	36 (91.4)	48 (121.9)
Cutting Height – in. (cm)	1.5 – 4.0 (3.8 – 10.2)	
Cutting Height Increments – in. (cm)	0.25 (0.64)	

www.husqvarna.com

115 73 95-27 Rev A

2015-01-15